

Children's Sampler



Sampler Collection

A sampler tells a story, capturing the events and emotions of a particular time. The Colonial Williamsburg Foundation's important collection of samplers and needlework, dating from the 17th century to the mid-19th century, includes a diverse selection of British and American needlework that help us trace the roots of their makers and better understand the world in which they lived. The samplers and individual design elements of this collection are taken from samplers and other needlework in the Foundation's collection.

Derived from the Latin "exemplum" meaning example, samplers usually included examples of a variety of stitches used as a teaching tool for young schoolgirls. In addition to learning practical stitching techniques, lessons in the alphabet, numbers, religion, art, and geography were reinforced.

To learn more about Colonial Williamsburg visit
www.williamsburg.com

Williamsburg

WILLIAMSBURG is a trademark of
The Colonial Williamsburg Foundation

Be sure to visit www.windhamfabrics.com to see the complete collection and to download this and other Free Projects

 Windham Fabrics

812 Jersey Ave ~ Jersey City, NJ 07310 ~ 201.659.0444 ~ FAX: 201.659.9719 ~ info@windhamfabrics.com

P R O J E C T

Children's Sampler

Designed by Joanie Holton & Melanie Greseth



Featuring Fabrics from the
Colonial Williamsburg Sampler Collection

 Windham Fabrics

Children's Sampler

Designed by Joanie Holton & Melanie Greseth
Featuring fabrics from the Sampler Collection
for Colonial Williamsburg
Quilt size: 45" x 50"

FABRIC	YARDAGE	CUTTING INSTRUCTIONS
29722-5 sampler squares	1 yd	(8) Fussy cut 7-1/2" x 8-1/2" squares (* Fussy cut 3-5/8" x 4"
29721-4 red sampler stripe	1/4 yd	(* Fussy cut 3-5/8" x 4" (*16 total between 29722-5 & 29721-4)
29721-1 green sampler stripe	1/2 yd	(17) Fussy cut 2-3/8" x 7-1/2"
29724-1 green scallop	1/8 yd	(24) Template A
29728-2 blue cross-stitch ch	1/4 yd	(20) Template D
29724-7 rose scallop	1/8 yd	(28) Template A
29720-2 blue floral	3/4 yd	outer border: (2) 4" x 43-1/2", (2) 4" x 45-1/2"(pieced)
29724-2 blue scallop	1/8 yd	(20) Template A
29728-1 green cross-stitch	1/4 yd	(24) Template D
29723-x alphabet	1/4 yd	(16) Fussy cut 3-5/8" x 4"
29728-5 red cross-stitch	1/4 yd	(28) Template D
29725-2 blue stripe	1/3 yd	inside border: (2) 2" x 40-1/2", (2) 2" x 38-1/2"

Backing/Batting 3-1/8 yards

BLOCKS:

Sew (1) Template A triangles (blue scallop) to (1) Template D triangles (blue cross-stitch). Repeat to make another of the same triangle set. Sew two new triangle sets together to make block B. Press. Repeat to make 12 green blocks, 10 blue blocks and 14 rose blocks.

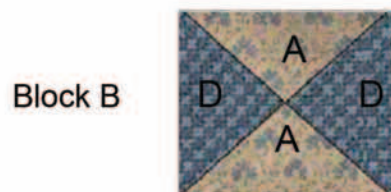

Referring to the quilt picture for placement.

Sew block B to fussy cut 3-5/8" x 4" blocks
(alphabet or sampler blocks.)

Repeat to make 32 sets.



Sew 2 block set to top and bottom of fussy cut 2-1/4" x 7-1/2" green sampler strips.

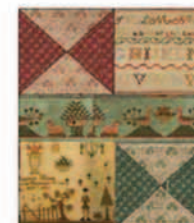

Center block:

Sew (1) blue block to (1) red block

Sew this set to the top of fussy cut 2-3/8" x 7-1/2" green sampler strip.

Sew (1) red block to (1) green block and sew to the bottom of green sampler strip.



Referring to the quilt picture for placement.

Layout blocks and fussy cut 7-1/2" x 8-1/2" squares. Sew blocks together in rows.

Sew rows together.

BORDERS:

Sew (2) 2" x 40-1/2" stripe strips to right and left sides.

Add (2) 2" x 38-1/2" stripe strips to top and bottom. Press.

Add (2) 4" x 43-1/2" blue floral strips to right and left sides.

Sew (2) 4" x 45-1/2" blue floral strips to top and bottom. Press.

Layer quilt top, batting and backing and quilt to finish. Bind.

Children's Sampler

TEMPLATES

Template A

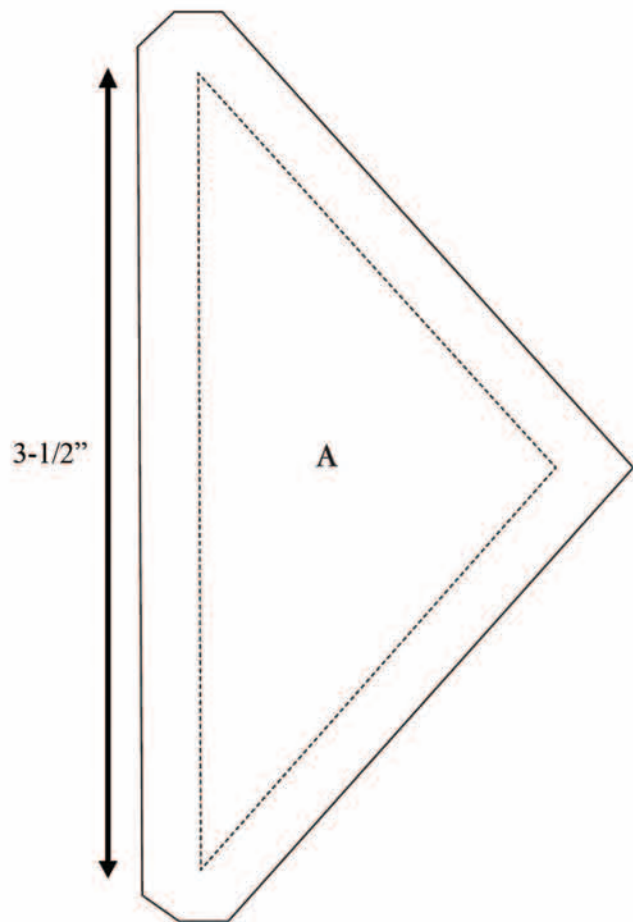

Template D

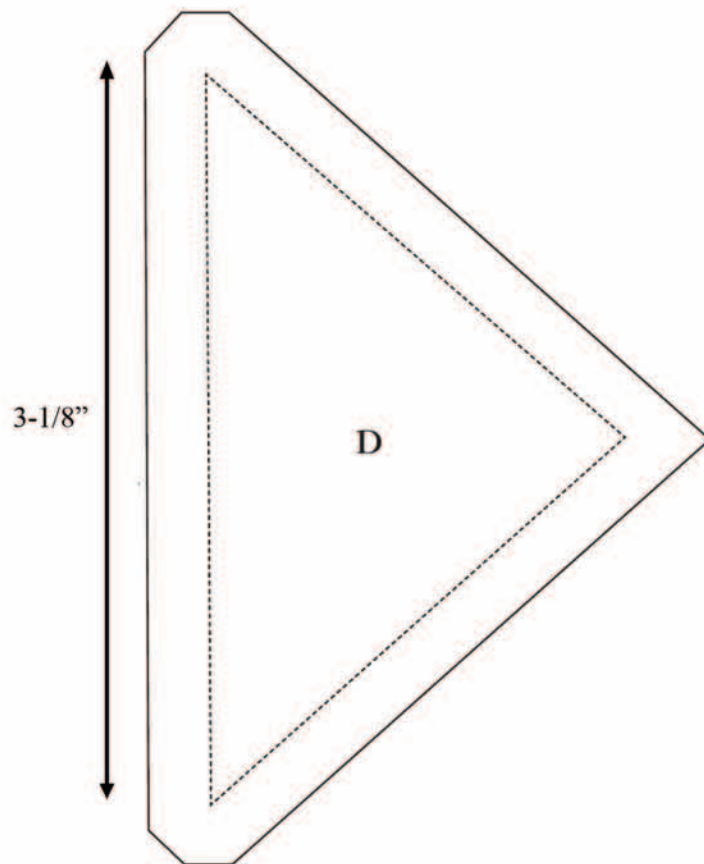

Some printers will alter the size of the template so be sure your template measures according to the size measurement given on long side of each template before using.

1/4" seam allowance not included in the measurement